

February 18, 2026

Del Mar Design Review Board
C/o Elizabeth Yee, Associate Planner
City of Del Mar
1050 Camino Del Mar
Del Mar, California 92014

Re: Harrington Residence
101 11th Street, Del Mar, CA 92014
DRB24-011 / LC24-008 / CDP24-028

Dear Design Review Board,

The Harrington Family purchased 101 11th Street about four years ago and have been in pursuit of improving the property since the first days of taking possession. They undertook construction of two ADU's with one off the alley and one at the midpoint of the lot. These units are now virtually complete and will be available for rent soon.

In the meantime, we have pursued the proposed design for a replacement home for the main house at 101 11th Street. We have matriculated through the CPP DRB processes and have taken into consideration the concerns and comments made by surrounding neighbors and the Board, and we have been able to create a new design that the Harringtons are pleased with and hopefully neighbors can appreciate for the compromises and efforts made to address concerns.

The current design is in response to the comments from the previous design that was presented to the DRB on May 28, 2025. The significant changes are:

Disconnecting the main house from the existing ADU. The current design no longer spans over the pool to rest atop the ADU. It now functions as a more compact and less elongated plan.

Reduction in Second Floor Area Size. The second story is now **300 square feet** smaller than the previous design by reallocating the area to a second bedroom on the first floor. This significantly reduces the bulk and mass of the second story.

The house has been lowered 2 feet from the previous design. The ceiling heights have been decreased some but most of the reduction is achieved by having the proposed first floor lower than the existing home's first floor which has a raised foundation. The new design sits more squarely on the existing adjacent

grade. The design requires less grading than the previous design and is more subservient to the topography.

Portions of the house are now closer to the street. In order to separate the home from the existing ADU the stair element of the design is now a little closer to 11th Street, yet it is still not at the front yard setback and is in keeping with the pattern of development of most if not all the homes on the south side of 11th Street. We have held the stair element away from the northwestern corner to preserve private views and public views that look across this diagonal corner at the foot of 11th Street. These views are not only of the Ocean but the Monterey Cypress tree as well.

Alley Fencing. Due to the requested easement, the alley fencing no longer captures the Harrington property that extends west of the alley. The newly proposed fencing now aligns with all other fences that run along the full extent of the alley.

We have strived to develop a solution that works best for the Harringtons and the neighborhood. In all we think it is a thoughtful compact 2,600 square foot home design that will be a great addition to the neighborhood. If you would like to schedule a time to visit the property with me and see the story poles, please reach out and I will make myself available.

Respectfully,

Jim Sneed
Bokal & Sneed Architects
(o) 858-481-8244
(c) 858-775-4757

From: Susan Harrington <susancharrington22@gmail.com>
Sent: Friday, February 20, 2026 5:20 PM
To: Elizabeth Yee
Subject: DRB Meeting, 101 11th St., Del Mar, CA

CAUTION: This email originated from outside of the organization. Do not click links or open attachments unless you recognize the sender and know the content is safe.

Design Review Board Members,

This is our third appearance before the DRB regarding our home at 101 11th Street. We have worked diligently to address all concerns raised and, after four years of collaboration with the City, we respectfully believe it is time for our project to be granted a building permit. Over these years, we have become deeply invested members of the Del Mar Community. We are proud to support local projects and organizations, including serving as “whale” contributors to the powerhouse Park Playground and as significant donors to the Del Mar Foundation, Friends of Powerhouse Park, The Winston School, and Community Connections, where Susan serves on the special events committee. We also actively support other local businesses, and are committed to continuing our involvement in meaningful and positive ways.

We fully recognize what a special and unique property 101 11th Street is, and we have approached this project with genuine care, love and respect for its setting. Our vision has always been to create a home that is welcoming rather than ostentatious—a place where we can host community gatherings and contribute to the social fabric of Del Mar. Unfortunately, despite our best efforts, this process has been repeatedly prolonged.

We have a legal right to build this home, and equally important to us is being thoughtful and respectful neighbors. We are sincerely grateful to those who have offered support along the way. We respectfully ask the Board to allow us to move beyond this phase, by granting the building permit, so we may begin construction on what we consider to be our final home—the place where we hope to grow old (or, at least older!).

Thank you for your time, consideration, and service to the community,

Warm regards,

Susan Harrington

Sent from my iPad



From: Becky Robbins <beckyrobbins1@gmail.com>
Sent: Saturday, February 21, 2026 4:46 PM
To: Elizabeth Yee
Subject: Recommendation

CAUTION: This email originated from outside of the organization. Do not click links or open attachments unless you recognize the sender and know the content is safe.

To the Design Review Board,

I would like to offer my encouragement to you regarding Tom and Susan Harrington as they build on the property on 11th Street in Del Mar. I actually lived on that street for awhile and now reside on Ocean Avenue in the most wonderful city ever. When I moved from Colorado in 1984, I chose Del Mar!

I have known the Harringtons for 10 years since moving to Ocean Avenue and treasure them as delightful friends and neighbors. We have been in one another's homes, we have enjoyed fireworks together at another mutual friend's home next door and it's always so pleasant. I was also impressed when Susan decided the necessity of improving the playground at Powerhouse Park because I also have grandchildren who visit frequently. I was more than happy to contribute to that.

I am a Trustee on the Board of La Jolla Playhouse and I know how important it is to support and contribute to our community. If I were on the Design Review Board I would also consider it to be a responsibility to our fine city of Del Mar and I truly would approve the plans that they have created for that beautiful property. I have been invited to see what they have built so far and every detail is impeccable as are the Harringtons and that is important not only to me as a neighbor but to Del Mar in particular. Integrity is paramount here and I thank you for your role on this board. I am eager to see this approved so we can all enjoy the finished construction. I thank you in advance.

Warmly,

Becky Robbins
1335 Ocean Ave
Del Mar, CA
858-442-7199

Nicole Morrow

From: Stuart JM Collinson <collinsons@yahoo.com>
Sent: Friday, February 20, 2026 12:30 PM
To: Planning Mail Box
Cc: Jean Crutchfield
Subject: Written Comments: DRB25-020, LC25-005, CDP25-017 / 422 Culebra development

Follow Up Flag: Follow up
Flag Status: Completed

CAUTION: This email originated from outside of the organization. Do not click links or open attachments unless you recognize the sender and know the content is safe.

Dear Jean

We are writing to express our support for the 422 Culebra development of building and landscape plans (and notes) as they have been presented.

Best regards

Stuart and Heather Collinson
1934 Zapo Street, Del Mar CA 92014

From: Matthew Burr <matthewb@wallacecunningham.com>
Sent: Friday, February 20, 2026 12:36 PM
To: Jean Crutchfield
Cc: Wallace Cunningham; 'Stuart JM Collinson'; 'Heather Collinson'; PB Bone
Subject: Rao Residence (422 Culebra) - Neighbor Correspondence

Follow Up Flag: Follow up
Flag Status: Flagged

CAUTION: This email originated from outside of the organization. Do not click links or open attachments unless you recognize the sender and know the content is safe.

Hi Jean,

Wally and I met with Pat Bone and Heather & Stuart Collinson in person at their properties, Monday, February 9th at 2:30pm. We reviewed the drawings and renderings and discussed their concerns to protect their ocean views. We also clarified that the roof is the same shape and material (Zinc.) as the previous design. There will not be any skylights or chimneys. After that meeting, we sent them follow up information. We informed them that there are four existing trees within the front yard that will be removed as part of the development project which will certainly help with their views. We shared their primary living area view renderings with them along with new 3D renderings

I wanted to also let you know that I corresponded and spoke with Heather & Stuart Collinson on a couple different occasions after that on-site meeting. As a result of those conversations our team has made the following changes to the landscape plan:

- Removed three citrus trees and two yuca trees in the area of the existing deck restoration on the east side of the property. We replaced those five trees with [Ceanothus griseus horizontalis 'Yankee Point'](#) that is max. 3' in height.
- Changed the triangular area on the east side of the property to existing slope planting (gray hatch).
- Added a note to the gray hatch area on the east side of the property to say, "maintain planting to a maximum height of 2'-3'".

In addition to those landscape changes, we highlighted on the plan below where the pool fence is. We also clarified that we are not proposing any additional fencing. In the case of the eastern area (shown in grey and pink below, abutting the Collinson & Bone properties) there would be no fencing now or in the future in this area.

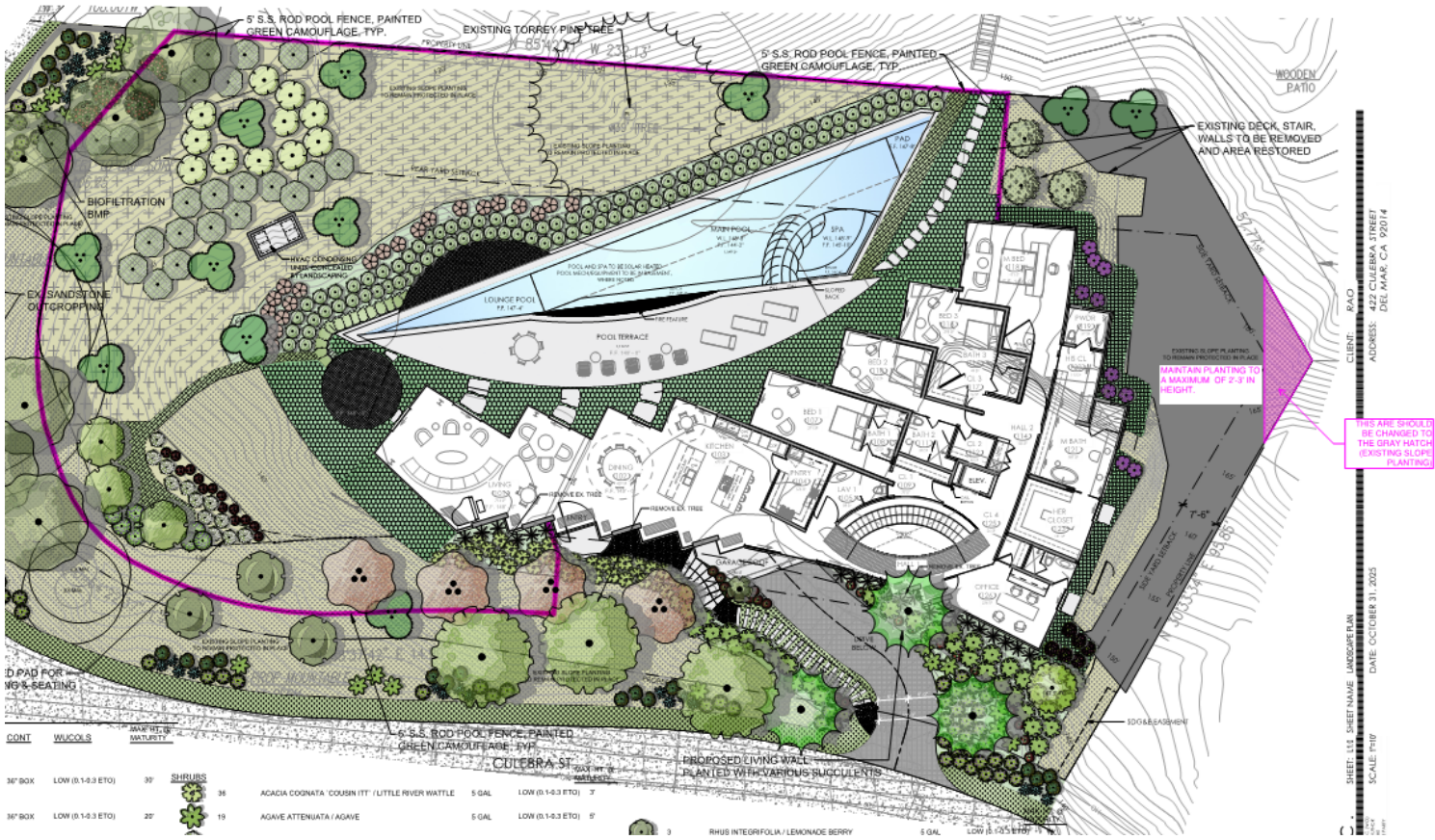

Please use this email as documentation of those changes. Please see click on the link below for the revised Architectural Site Plan A1.1 and landscape sheets. Please let us know if you have any questions.

Link to revised drawings: <https://wallacecunningham.sharefile.com/public/share/web-sfc475168b5934c17a300208eebbe6a4e>

Thanks Jean!

matthew c.burr, vice president

WALLACE E. CUNNINGHAM, INC.
 t. 619-293-7640 ext.2
 f. 619-293-0624 c. 858-716-7788

February 23, 2026
Del Mar Design Review Board
C/o Elizabeth Yee, City Planner
City of Del Mar
1050 Camino Del Mar
Del Mar, California 92014

Re: Raduenz Residence DRB Mod-25-003
206 13th Street

Dear Design Review Board,

The Raduenz family would like to amend their current application before you in two areas. The first being the location of the condensing units and the second being the front door stoop design and configuration.

Condensing Unit Locations:

Now that we are under construction, we are having difficulty fitting all the condensing units in the designated utility area next to the alley. First, we are finding the need for 4 units rather than the 3 that we anticipated during the schematic design review stage of the project. One unit for each level of the home and one unit for the ADU is needed for maximum efficiency. Within the utility area we also are having to locate the gas service and meter, electric service and meter, as well as the main water line and the originally proposed trash receptacles. All these utilities have their separate size requirements and clearances.

We are locating the largest unit (FAU#1) for the main living area which will be the most highly used unit and a smaller unit (FAU#2) for the ADU in the utility area off the Alley. The Master bedroom unit and the basement unit (FAU#2 & #3) are smaller units and would be on the first story roof above the pantry and next to side yard in the rear third of the lot. These units will be surrounded by a 42" tall sound attenuating wall.

We think this mid lot location is appropriate because it the only impacts, if any, are to the property to the south which is owned by the Raduenz family. The neighboring home on that property is not at the setback and is approximately 30 feet away from the proposed unit location. The position aligns mostly with the neighboring garage. The Raduenz family feels confident this will not negatively affect them or any future owner.

Front Door Stoop:

The attached front door stoop revision lies within the footprint of the submitted revision in your packet. This revision merely adds an arch to that projection.

If you have

Jim Sneed

Bokal & Sneed Architects

(o) 858-481-8244

(c) 858-775-4757

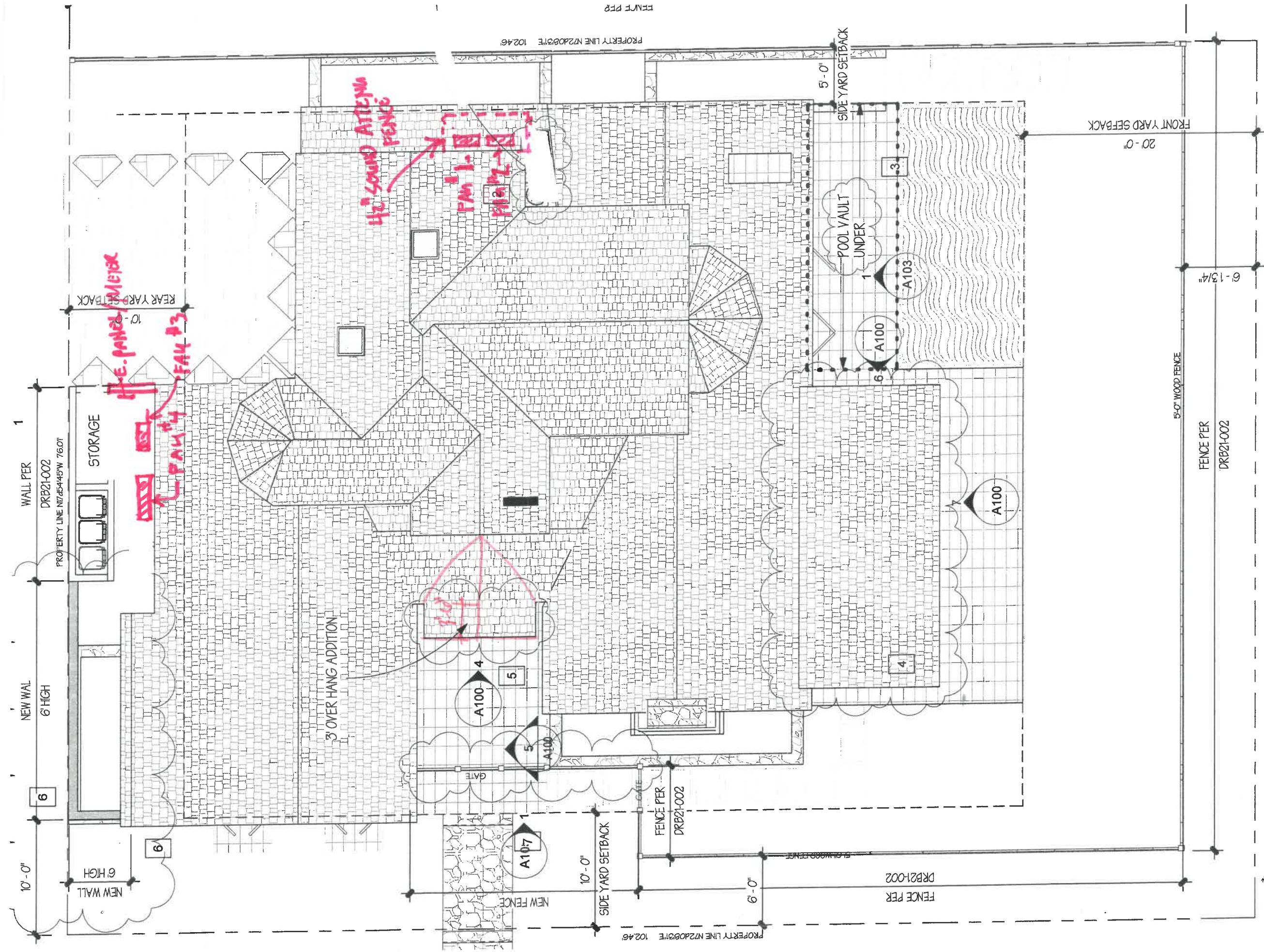

1 NEW MOD SITE PLAN
1/8" = 1'-0"



NORTH

RADUENZ
207 15th St.

DRB 25-003

PROPERTY LINE N72D031E 102.46'

5'-0" WOOD FENCE

FENCE PER
DRB21-002

FRONT YARD SETBACK
20'-0"

6'-13/4"

5'-0"
SIDE YARD SETBACK

POOL VAULT
UNDER

NEW FENCE

10'-0"
SIDE YARD SETBACK

FENCE PER
DRB21-002

6'-0"

FENCE PER
DRB21-002

PROPERTY LINE N72D031E 102.46'

PROPERTY LINE N72D031E 102.46'

FENCE PER

Air Handler Size	A (in)	22	18 1/2	17	20.35
AX182A	36				
AX241A	41	22			
AX240B			21		20.08
AX242B				20	
AX361B			21 7/8		24.6
AX300C	26				
AX360C					

Dimensions

Table 4: Dimensions

Unit model	Dimensions (in.)			Refrigerant connection service valve (in.)	
	A	B	C	Liquid	Vapor
HH824EZS11	29 1/2	35 3/7	13 2/5	3/8	5/8
HH836EZS11	34 4/9	43 1/3	17 5/7		3/4
HH860EZS11	57 1/2	38 2/5	13		7/8

FAU #1, #3 →
 FAU #4 →

Figure 2: Dimensions

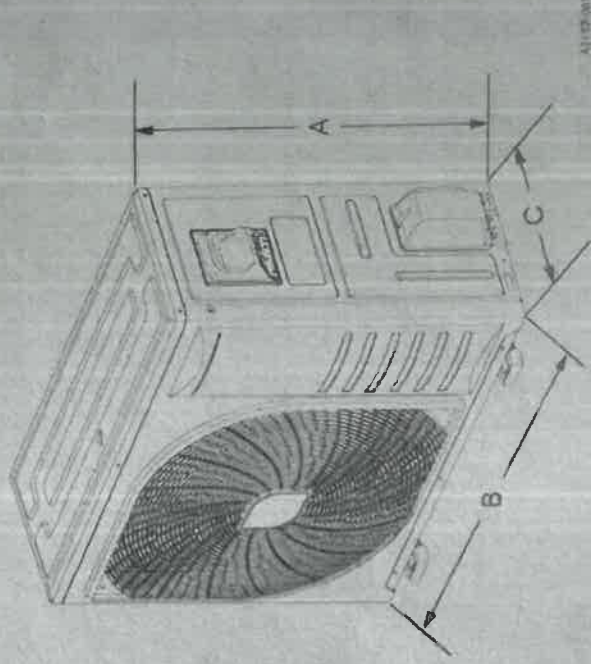

Dimensions notes

- All dimensions are in inches and are subject to change without notice.
- The overall height is from the bottom of the base pan to the top of the fan guard.
- The overall length and width include screw heads.

RADYENZ
 207 13th St.

DRB MP 25-023

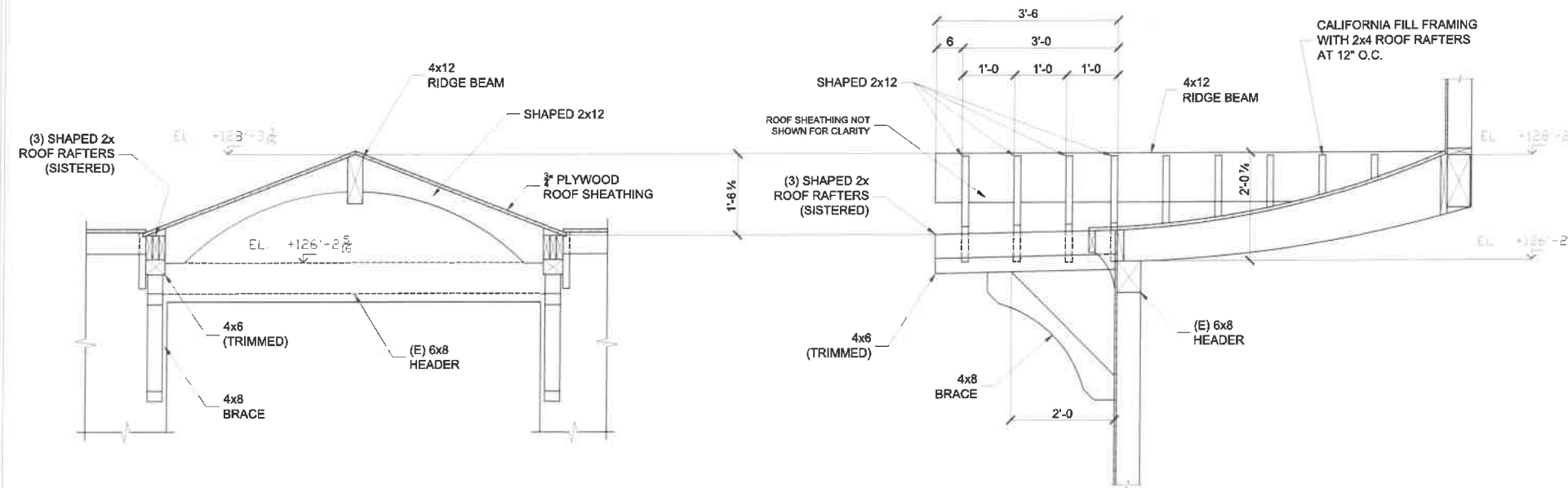

ENTRY FRONT VIEW STRUCTURAL

ENTRY SIDE VIEW STRUCTURAL

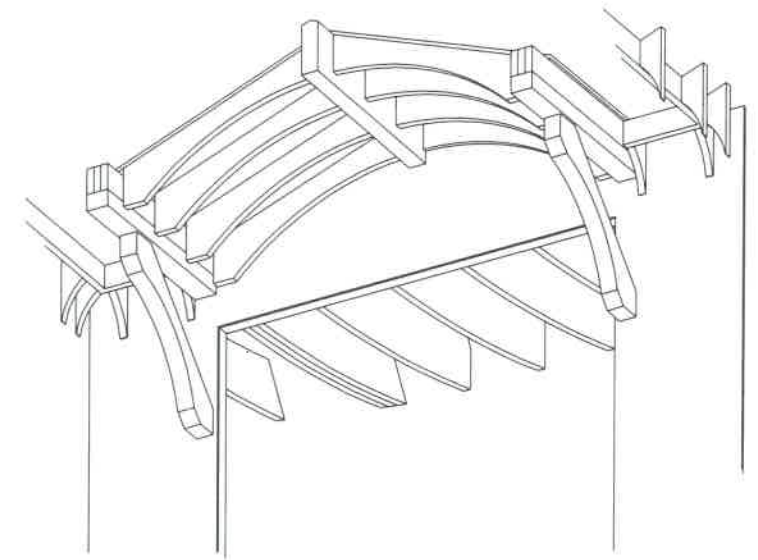

3D VIEW STRUCTURAL

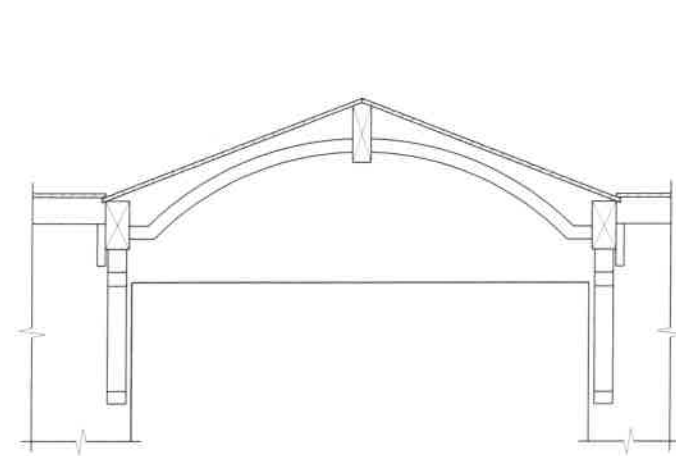

ENTRY FRONT VIEW FINISHED

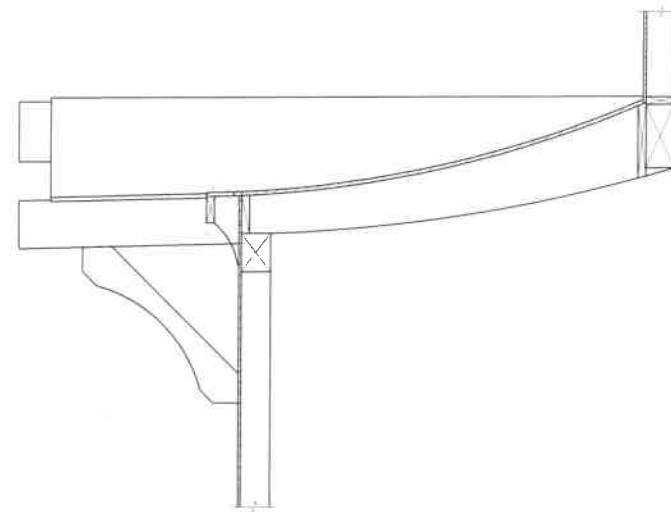

ENTRY SIDE VIEW FINISHED

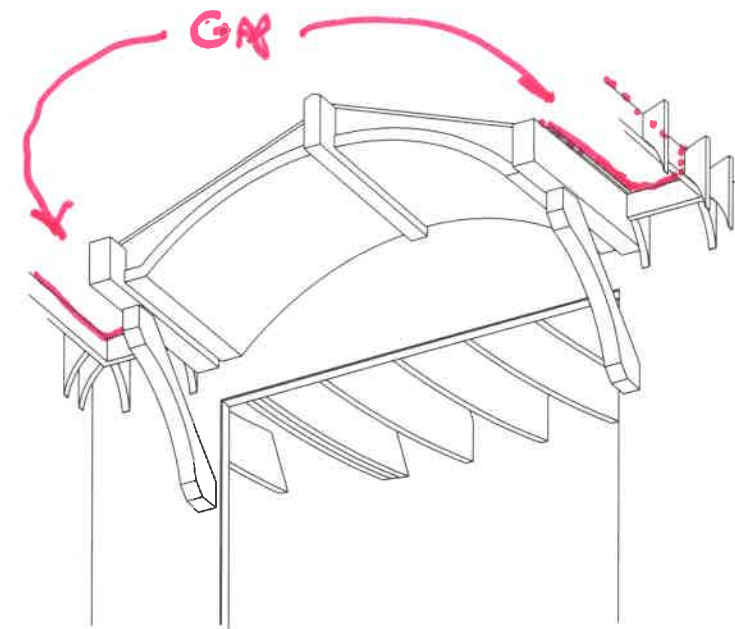

3D VIEW FINISHED

*RADUENZ
207 13th St.*

DRS MODS-003

REV.	Date	BY	Description
DANA CONSTRUCTION			315 SOUTH COAST HWY SUITE U53 Encinitas, CA 92024 (760) 807-3373
Project: RADUENZ RESIDENCE			
Address: 207 13th STREET, DEL MAR			
Project No.: 2538			
Client:		Contractor: DANA CONSTRUCTION	
Architect: BOKAL & SNEED		Engineer: BWE, INC.	
Coating:		Description: NEW AWNING OVER ENTRY	
Holes:	Detailer: PDS	Phase:	
Weld:	Checker:	Drawing No.:	
Status:	Date: 2/9/2026	LO-22	

From: Robert Silva
Sent: Monday, February 23, 2026 5:40 PM
To: Planning Mail Box
Subject: FW: SUPPORT LETTER: DRB agenda item: 101 11 th St, 107LLC, Thomas Harrington, HEARING scheduled for Wed., Feb. 25, 2026 at 6 PM

Robert Silva | Administrative Assistant
City of Del Mar | Administrative Services Department
1050 Camino del Mar, Del Mar, CA 92014
Direct Line | 858-375-9526 | rsilva@delmar.ca.us



CITY OF DEL MAR

From: Darcy Bingham <dcbingham@mac.com>
Sent: Monday, February 23, 2026 4:38 PM
To: City Clerk Mail Box <CityClerk@delmar.ca.us>
Cc: Thomas Harrington <tomharrington44@gmail.com>; Richard Bokal <rbokal@bokalandsneed.com>; jsneed@bokalandsneed.com
Subject: SUPPORT LETTER: DRB agenda item: 101 11 th St, 107LLC, Thomas Harrington, HEARING scheduled for Wed., Feb. 25, 2026 at 6 PM

CAUTION: This email originated from outside of the organization. Do not click links or open attachments unless you recognize the sender and know the content is safe.

Greetings DRB members,

This letter is in FULL SUPPORT of the Harringtons' proposed build at 101 11th Street.

We live at 140 11th Street, and have lived on the block for 25+ years. Our home is just up the street from this build, and the current home is, and new home will be, visible from our front yard and from multiple indoor living spaces.

Having built in the area ourselves, we know how tough it can be, and, unfortunately, how personal things can become. Significant modifications have already been made to address previous comments, the Bokal & Sneed design fits Del Mar's aesthetic, it's an extremely attractive home, and appropriate for the lot size, zoning and location.

We hope you will approve the project as currently submitted, and my husband and I will be pleased to welcome this beautiful new addition to our block.

Thank you for your commitment to our city and all of your efforts on behalf of Del Mar and those of us who reside here. You have a tough Job - Please know you and your thoughtfulness are appreciated.

Best regards,

Darcy & Robert Bingham
140 11th Street

Kindness matters.

From: Tanya Young <tanyayoungart@gmail.com>
Sent: Tuesday, February 24, 2026 9:47 AM
To: Planning Mail Box
Cc: Elizabeth Yee
Subject: Red Dot—DRB February 25, Item 1

CAUTION: This email originated from outside of the organization. Do not click links or open attachments unless you recognize the sender and know the content is safe.

Dear Respected Members of the DRB,

We are writing in support of Tom and Susan Harringtons' project at 101 11th St.

Tom and Susan with their architect Jim Sneed have been engaged with the Design Review Board during two previous meetings, responding to every concern of neighbors and the Board and making significant concessions. One hopes that at this meeting they may proceed to the construction phase with the granting of their permit.

I am most familiar with the Harringtons as great friends of our Del Mar community. At Del Mar Community Connections where I am a Board member, Tom and Susan are among our Sustaining Members, at our highest level of giving, for which we are truly grateful. Tom and Susan are also generous in sharing their time, talent and positivity. Susan has served on the DMCC Special Events committee, and she recently joined the Nominating Committee of which I am Chair. Susan and Tom are active supporters of DMCC, which serves Del Mar seniors.

We are confident that their project will be done to the highest standards of taste and craftsmanship using beautiful natural materials.

I feel personally fortunate that Tom and Susan Harrington are part of our community. We encourage you the DRB to grant the permit to the Harrington project at 101 11th Street.

Sincerely,

Tanya Young and Michael McManus
919 Klish Way

Tanya Young Studio
858.382.3636
tanyayoungart.com
www.facebook.com/tanyayoungscienceillustration
Instagram: tanya_young_studio
X: @tanyayoungart

Elizabeth Yee

From: Gregory Beckham <grbeckham@gmail.com>
Sent: Monday, February 23, 2026 10:47 AM
To: Elizabeth Yee
Subject: Harrington project

CAUTION: This email originated from outside of the organization. Do not click links or open attachments unless you recognize the sender and know the content is safe.

To whom it may concern,

I have been fortunate to have been a neighbor of the Harrington family for over twenty years on Ocean Ave and Penny lane, and I would like to encourage everyone to support their development application.

They have shown to be supportive and generous community members in civic and personal life consistently through the years, and always have the best interest for the quality of life in Del Mar.

They have hired excellent architects and builders and the project will be a credit to the neighborhood for generations to come.

Regards, Greg Beckham

Sent from my iPhone